

Product Overview

These free space modulators operate at 80MHz and at various wavelength ranges covering the 450-700 nm, 700-1100 nm and 980-1100 nm. The intended application can be amplitude modulation as well as frequency shifting (fixed and variable).



Features

- Small rise time
- Linear polarization
- High diffraction efficiency

		Units	Min	Nom	Max
Material-Acoustic mode-Velocity			TeO2 [L] – 4200 m/s		
Optical Wavelength range (AR coated) (λ)	VIS	nm	450		700
	IR		700		1100
	1064		980		1100
Carrier Frequency / Frequency shift		MHz	+/-80		
Transmission		%	95	98	
Input / Output Polarization			Linear / Linear		
Active Aperture		mm ²	1 x 2		
Beam diameter (1/e ²)(φ)		mm	0.5		1
Rise/fall time (T _r)		ns	80		160
Analog Amplitude Modulation Bandwidth (-3dB) (F _{-3dB})		MHz			6
Separation Angle (0-1)	VIS	mrd	8.6		13.3
	IR		13.3		21
	1064		18.7		21
Static Extinction Ratio		dB	30		
*Diffraction Efficiency (η)		%	85		
Optical power density (CW)	VIS	W/mm ²			5
	IR/1064				10
Input impedance		Ω		50	
V.S.W.R.				< 1.2:1	
RF Power (P)	VIS	W			1
	IR/1064				2,2
Size		mm ³	50.9 x 22.4 x 17.3		
Weight		g		50	
Packaging			IN PRO 005		
Operating Temperature (non condensing)		°C	+10	+25	+40
Storage Temperature (non condensing)		°C	-20		+50
RoHS Compliance			Yes		
OPTION MT80-B30A1-xx			Frequency range 80+/-15MHz, Efficiency typ >60% over full range		

* Diffraction efficiency is beam diameter and wavelength dependent.

$$T_r = 0.66 \frac{\phi}{V} * F_{-3dB} = \frac{0.48}{T_r} * \Delta\theta = \frac{\lambda F}{V} * \frac{P_1}{P_2} = \frac{\lambda_1}{\lambda_2}$$

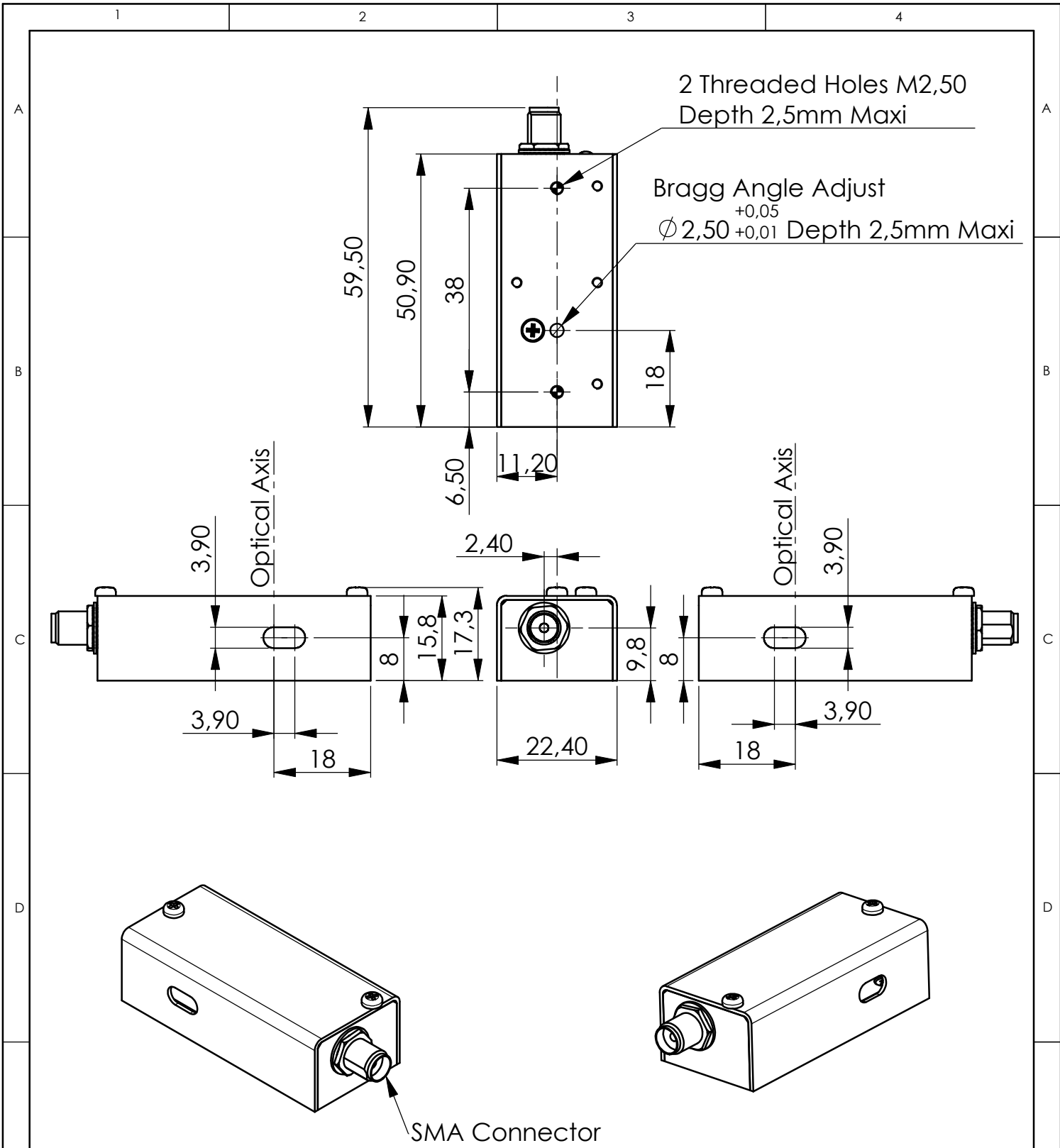

B	18/12/06	E.D	Reprise mise en plan
A	15/10/03	F.C	Plan initial / Initial Drawing
Indice Index	Date	Auteur Author	Modifications
Conception Design	E.D	PLAN D'INTERFACE / OUTLINE DRAWING Référence / Reference IN-PRO-005	
Vérification Checking	L.F		
Tolérance Tolerance	ISO 2768mK		
Echelle Scale	1:1	 OPTO-ELECTRONIC A.A. SA OPTO-ELECTRONIQUE DIVISION 18, rue Nicolas Appert F-91898 ORSAY tel : 08 11 09 76 76 fax : 01 76 91 50 31	
	Format A4	Ce document est la propriété de A.A.SA. Il est strictement interdit de reproduire ce document ou une partie sans l'autorisation de A.A.SA. This document is the property of A.A.SA. It is strictly prohibited to reproduce this document or a part without the authorization of A.A.SA.	
		Folio / Sheet 1/1	Indice / Index B